

Tivoli Chair



Please read these instructions very carefully before you begin to ensure that your Futon Company sofa bed will give you many years of satisfaction

Thank you for buying a Futon Company product.

We are constantly striving to improve everything we do, but occasionally mistakes do occur. In the unlikely event that you find any part missing, please call your nearest Futon Company store and we will arrange for the despatch of an immediate replacement. Please keep all packaging until you have checked every part and assembly of your Futon Company product is complete.

Version: 1

Product Code: Tivoli Chair

ROPO 6144

experts in small space living



Part Checklist

Please count and check every component very carefully before you begin



1. Seat x 1



2. Leg x 2



3. Rotating Mechanism x 1



4. Plate x 1



Fittings Checklist

Please count and check every component very carefully before you begin

A



Allen Key x 1

B



Allen head bolt x 3
(25mm size)

C



Allen head bolt x 8
(30mm size)

D



Allen head bolt x 2
(18mm size)

E



Plastic cap x 2



How to assembly Tivoli Chair

Please follow these instructions carefully

FUTON

C O M P A N Y

Step 1

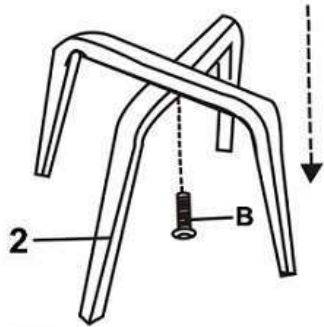

Step 2

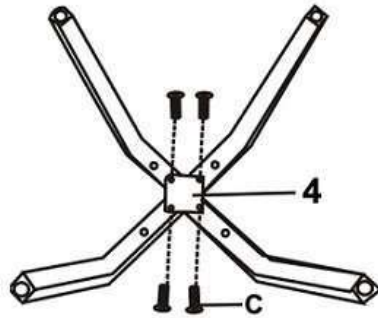

Step 3

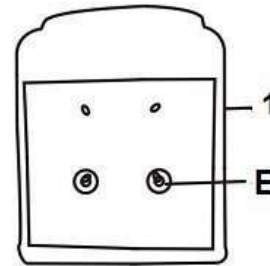

CARE

It is advisable to wipe off any liquid or stain on the fabric immediately and clean it with a mild detergent. Always test an area of unseen fabric first before to ensure detergent is suitable.

IMPORTANT

To ensure maximum performance from this product, we advise that you check and tighten all bolts and screws on a regular basis to avoid damage and strain to parts.

Improper use, improper assembly and mishandling may lead to product damage.

DO NOT STAND ON THIS CHAIR

GUARANTEE

This instruction leaflet forms part of your guarantee, please retain it. The ROPO number along with your invoice number will need to be quoted in all correspondence with Futon Company.

Thank you for choosing Futon Company.

Step 4

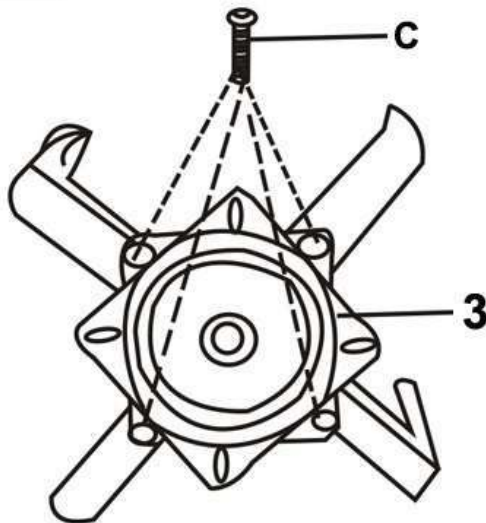

Step 5

