



How To Assemble Your Dressing Table

Please follow these instructions carefully

FUTON

C O M P A N Y



How To Use

Please read carefully

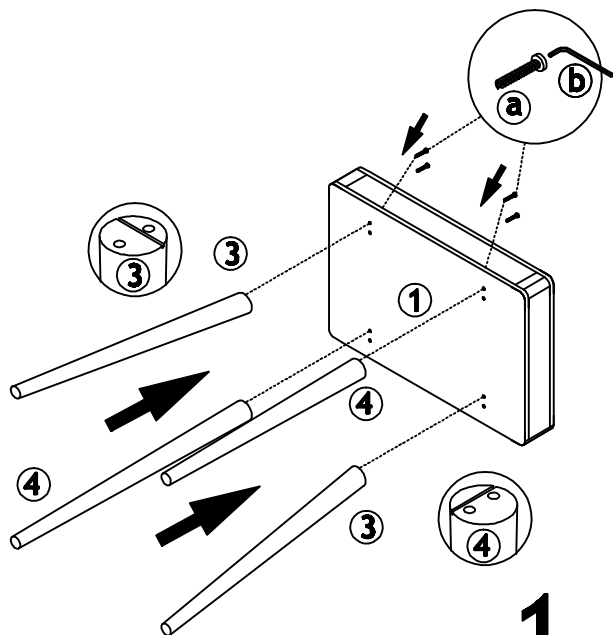

1.

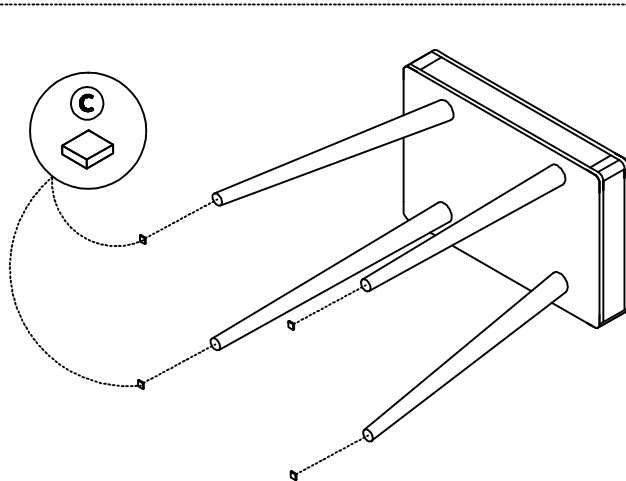

2.

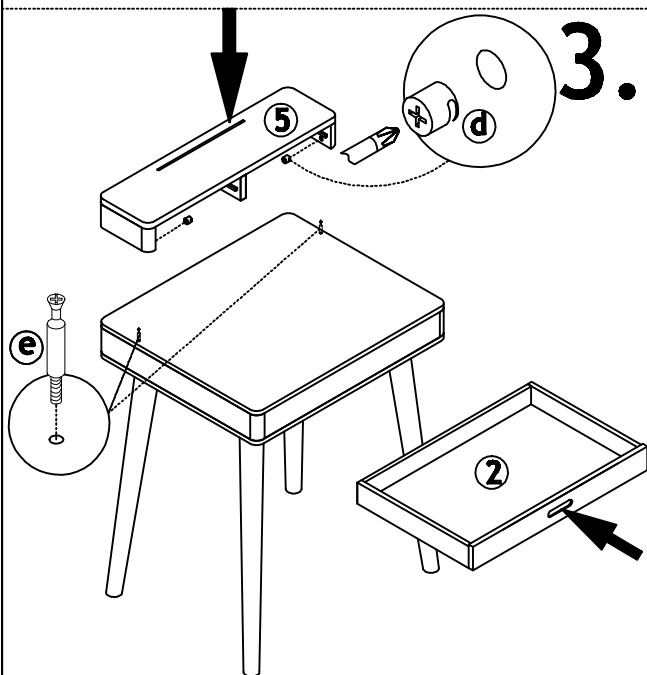

3.

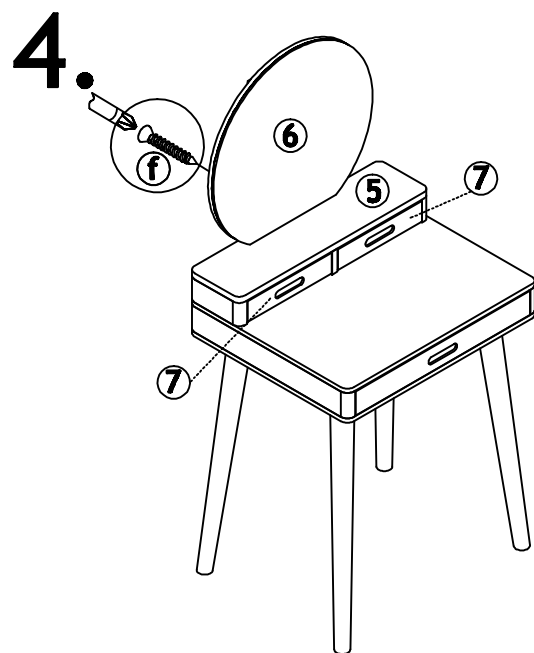

4.

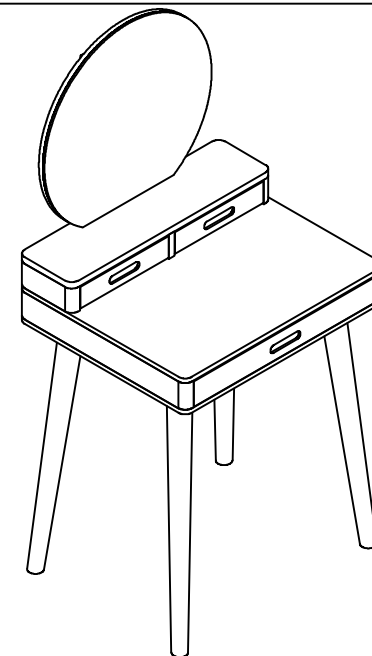

FINISH

Your Dressing Table is made from solid oak and has an oil and lacquer sation finish.

CARE

Wipe with a soft damp cloth. To spot clean your Dressing Table, rub with fine wire wool along the grain and very lightly re-oil with boiled linseed oil and allow 48 hours to dry.

IMPORTANT

To ensure maximum performance from this product, we advise that you check and tighten all bolts and screws on a regular basis to avoid damage and strain to parts.

GUARANTEE

This instruction leaflet forms part of your guarantee, please retain it. The ROPO number along with your invoice number will need to be quoted in all correspondence with Futon Company.

Thank you for choosing Futon Company.

Assembly Instructions



Dressing Table - Moonrise

ROPO no:

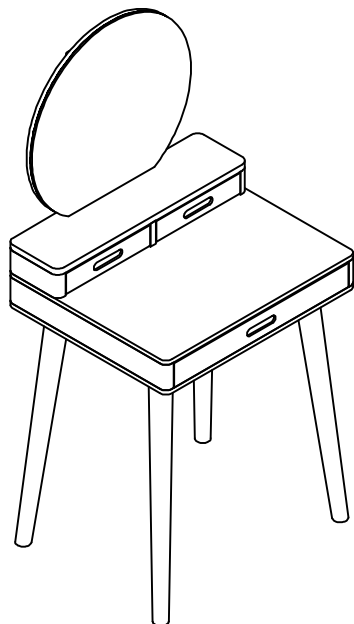

PLEASE READ THESE INSTRUCTIONS VERY CAREFULLY BEFORE YOU BEGIN, TO ENSURE THAT YOUR FUTON COMPANY PRODUCT WILL GIVE YOU MANY YEARS OF SATISFACTION

Thank you for buying Futon Company product

We are constantly striving to improve everything we do, but very occasionally mistakes do occur.

In the unlikely event that you find any part missing please call your nearest Futon Company store and we will arrange for the despatch of an immediate replacement.

Please keep all packaging until you have checked every part and assembly of your Futon Company product is complete.

Version number: 1

Product code: T4 MOONRISE

Date: 01/01/18

experts in small space living



Parts Checklist



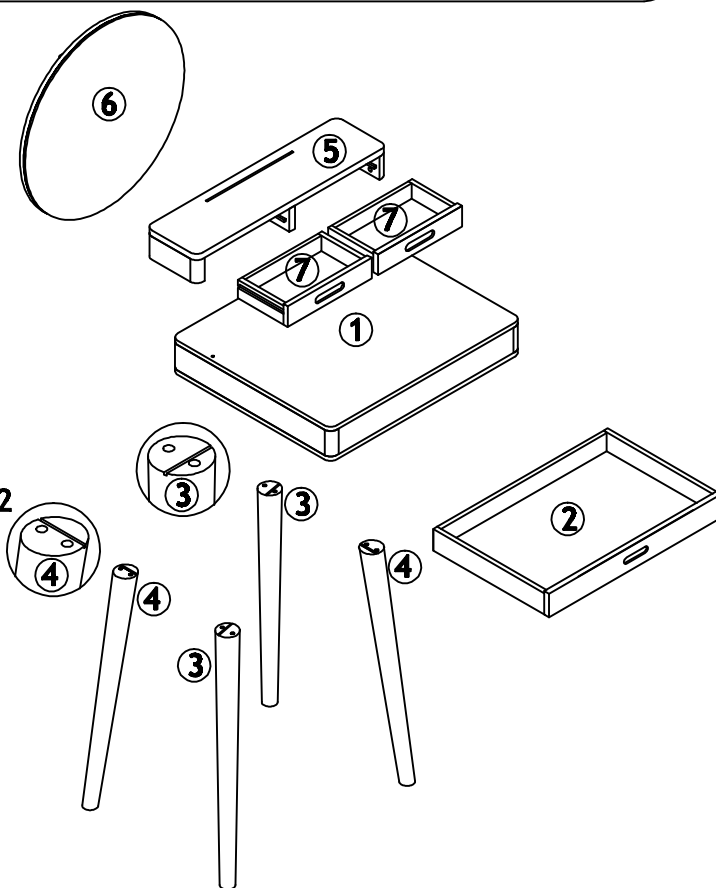

Please count and check every component very carefully before you begin

- ① Top x 1
- ② Big Drawer x 1
- ③ Leg-A x 2
- ④ Leg-B x 2
- ⑤ Upper Shelf x 1
- ⑥ Mirror x 1
- ⑦ Small Drawers x 2



Fittings Checklist

Please count and check every component very carefully before you begin

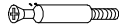
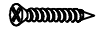
-  (a) Allen Head Bolt x 8
-  (b) Allen Key x 1
-  (c) Felt Protector Pad x 4
-  (d) Cam x 2
-  (e) Cam Bolt x 2
-  (f) Screw x 1

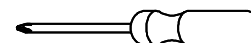

* Cross head Screwdriver also required for assembly